

WIRELESS SENSING UNITS WITH EMBEDDED ACTUATION AND DAMAGE DETECTION FUNCTIONALITY

Yang Wang, Jerome Peter Lynch and Kincho H. Law

In recent years, the structural engineering community has expressed significant interest in applying wireless sensing technologies within structural monitoring systems. Previous studies focused on wireless sensing units capable of “passively” collecting response measurements of a dynamic structural system at low-cost. To further extend this monitoring paradigm, recent research has been exploring the extension of wireless sensors by including in them capabilities to actuate the system. A wireless active sensing unit capable of exciting structural systems using a variety of actuators, collecting system responses, and analyzing the input-output time history data, is proposed. Figure 1 shows the architectural design of the proposed wireless active sensing unit.

As for demonstration purpose, a wireless active sensing unit prototype has been fabricated. A series of validation tests have been conducted to assess the unit’s performance. As one validation test, a piezoelectric pad mounted to an aluminum plate is commanded by the wireless active sensing unit to impart low energy Lamb waves in the plate surface. Simultaneously, the same unit is used to collect response measurements obtained from a second piezoelectric pad also surface-mounted on the plate. The computational core of the sensing unit is used to compute the ARX (autoregressive with exogenous inputs) time-series models using the time-history data collected from the excited system. Meanwhile, wireless communication between the sensing unit and a remote data server is employed to query a response database populated by ARX models corresponding to the undamaged structure. By comparing the newly computed ARX model of the structure in an unknown (potentially damaged) state with the undamaged database models, the wireless active sensing unit can potentially hypothesize the occurrence of subtle damage in the monitored structural component.

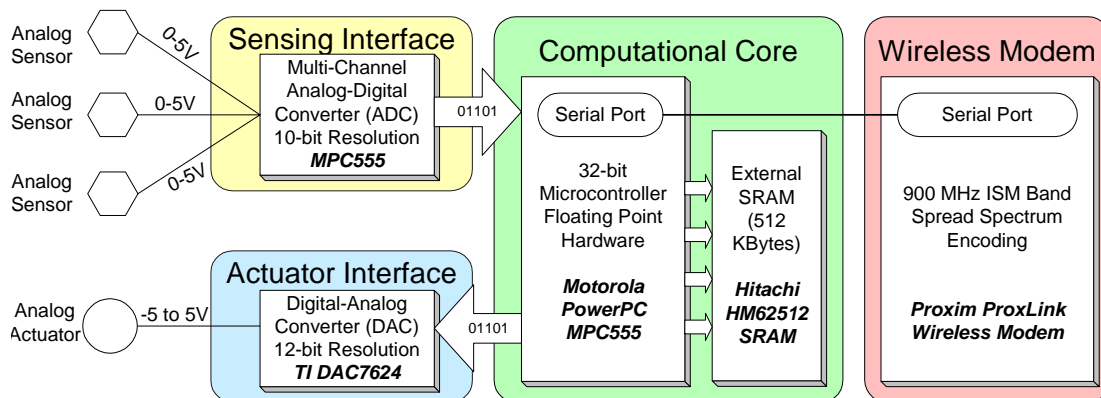

Figure 1 – Architectural design of the proposed wireless active sensing unit